

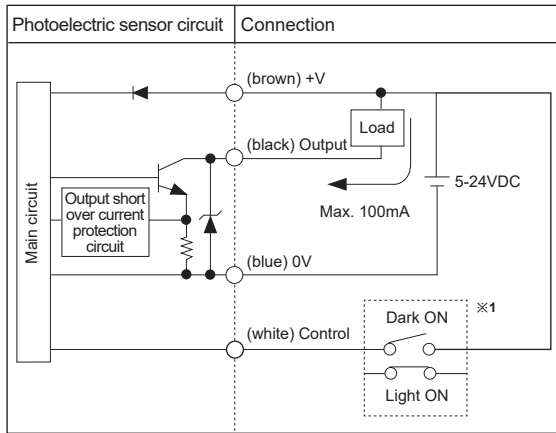

# BS5 Series

## Control Output Diagram

### • NPN open collector output



### • PNP open collector output

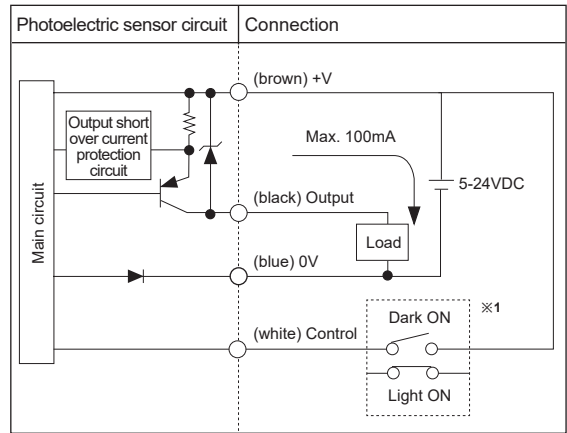

※1: Operation mode selection: Connect (white) Control (terminal) into terminal (brown) +V to operate Light ON mode. Dark ON mode is available with disconnection status.

※If short-circuit the control output terminal or supply current over the rated specification, normal control signal is not output due to the output short over current protection circuit.

## Connections

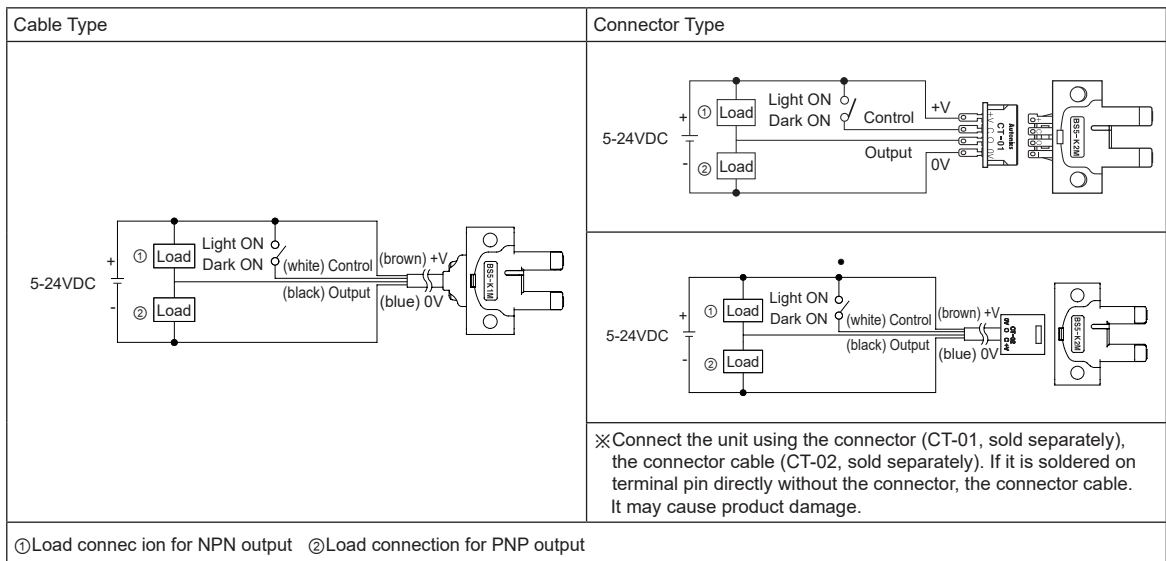

## Operation Mode

Operation mode	Light ON	Dark ON
Receiver operation	Received light  Interrupted light	Received light  Interrupted light
Operation indicator (red LED)	ON  OFF	ON  OFF
Transistor output	ON  OFF	ON  OFF

## ■ Dimensions

(unit: mm)

### ● BS5-K1M / BS5-K1M-P

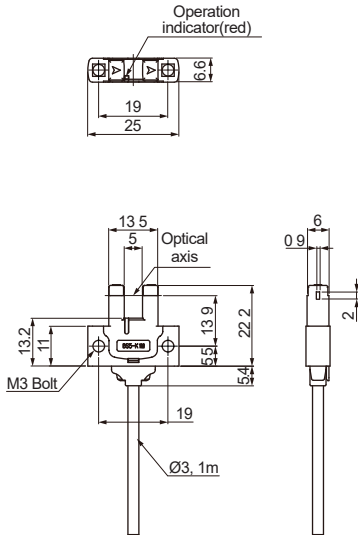

### ● BS5-T1M / BS5-T1M-P

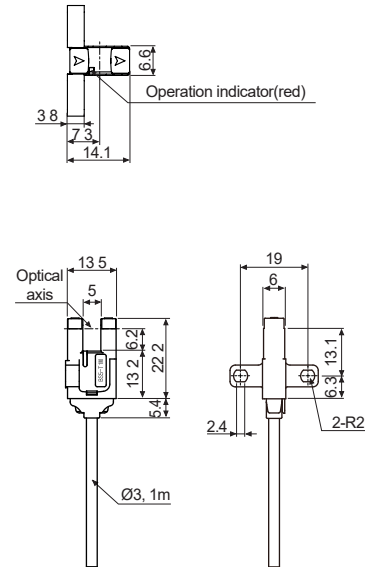

### ● BS5-L1M / BS5-L1M-P

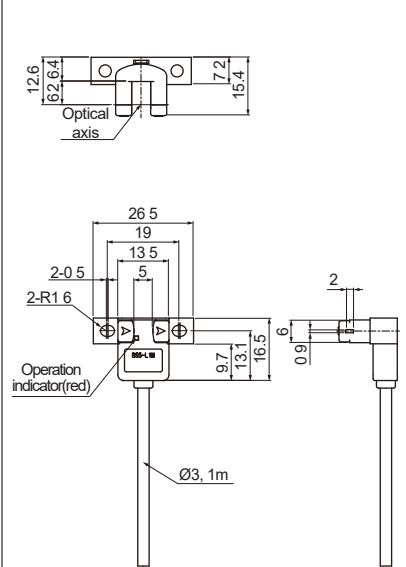

### ● BS5-V1M / BS5-V1M-P

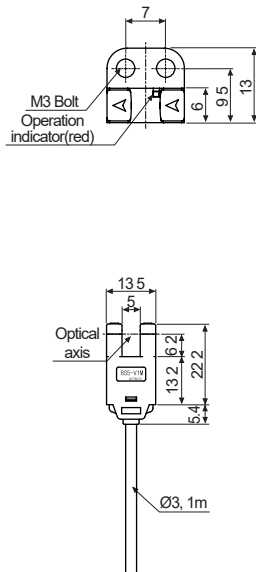

### ● BS5-Y1M / BS5-Y1M-P

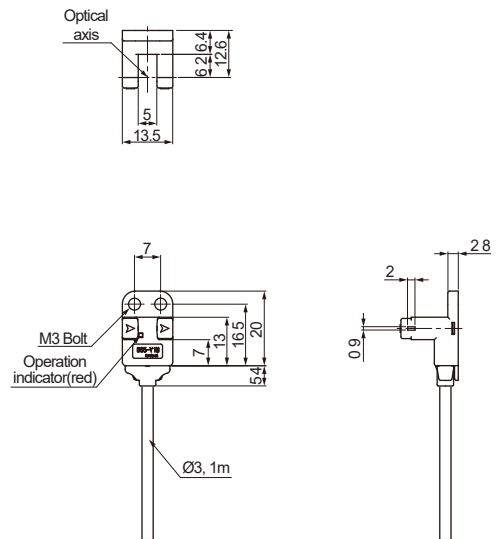

※When using photoelectric sensors closely over two units, it may result in malfunction due to mutual interference.  
 ※When installing the product, tighten the screw with a tightening torque of 0.49N·m.

SENSORS
CONTROLLERS
MOTION DEVICES
SOFTWARE

(A) Photoelectric Sensors
(B) Fiber Optic Sensors
(C) LiDAR
(D) Door/Area Sensors
(E) Vision Sensors
(F) Proximity Sensors
(G) Pressure Sensors
(H) Rotary Encoders
(I) Connectors/ Connector Cables/ Sensor Distribution Boxes/ Sockets

# BS5 Series

## ■ Dimensions

(unit: mm)

### ● BS5-K2M / BS5-K2M-P

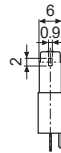
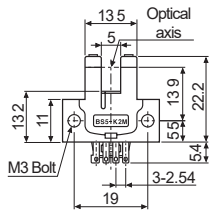
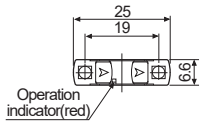

### ● BS5-T2M / BS5-T2M-P

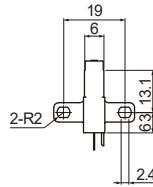
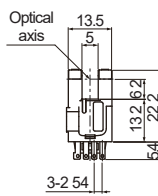
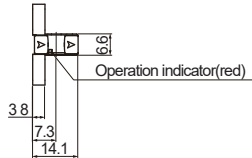

### ● BS5-L2M / BS5-L2M-P

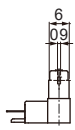
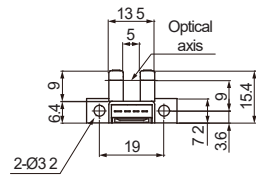
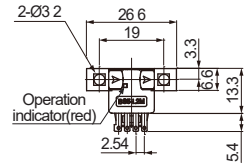

### ● BS5-V2M / BS5-V2M-P

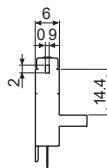
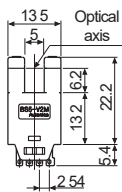
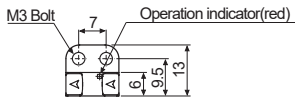

### ● BS5-Y2M / BS5-Y2M-P

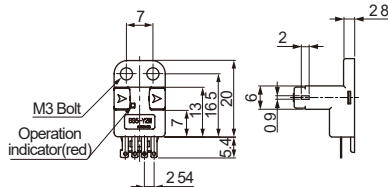
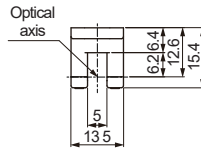

### ● Connector type (sold separately)

#### ● Connector (CT-01)

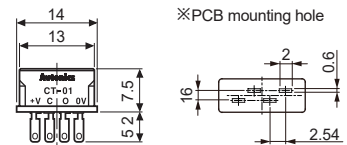
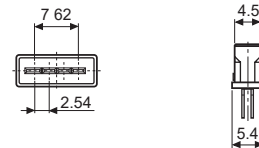

#### ● Connector (CT-02)

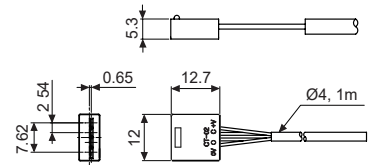

※ Cable: Ø4mm, 4-wire, 1m  
 (AWG22, Core wire diameter: 0.08mm,  
 No. of core wire: 60, Insulator out diameter:  
 Ø1.2mm)  
 ※ Cable length is available to option.